

BrightEye 76

HD / SD Analog to Digital Video Converter with Optical Out

BrightEye 76 is an analog video to digital converter and audio embedder. Standard definition component or composite, or high definition analog component video is accepted on the input BNCs. Two channels of analog audio are input on a plugable Phoenix connector.

This unit is perfect for use with HD cameras or other devices with analog I/O. The digital output will carry the full, uncompressed input, synchronous to a genlock reference. You can turn a hand-held HD camera into a digital source. A three camera, live studio suddenly becomes affordable.

The built-in TBC/Frame Synchronizer allows you to feed asynchronous or noisy signals to the BrightEye 76. The input is digitized to 12 bits of resolution and time base corrected by a noise tolerant tracking circuit. An external reference input allows genlock to a house reference.

Input selection, gain control, and TBC enable is provided through the front panel interface. Video levels can be adjusted through BrightEye Mac or PC software.

The video and audio signals are embedded and presented as an optical output. The output follows the SD or HD input standard.



- > Optical Transmitter
- > Use with Analog HD Cameras and Set Top Boxes
- > Turn Analog Camera Into Digital HD Source
- > Analog Component HD or SD Inputs
- > Analog Audio Inputs
- > Optical Embedded Output
- > TBC and Frame Sync

Analog Video Input

Number	One
Type	HD or SD :Y, Pr, Pb (SMPTE or Beta levels) HD or SD: Analog Component RGB (sync on green) Analog Composite PAL or NTSC Analog S-Video PAL or NTSC
Resolution	Digitized at 12 bits
Impedance	75 Ω
Return Loss	>40 dB
Input DC	+/-1 volt DC
Input Hum	<100 mV

Analog Audio Inputs

Number	Two
Type	Balanced
Impedance	>15K Ω
Maximum Input Level	24 dBu
CMRR	>60 dB, 20 Hz to 10 KHz
Quantization	24 bits, 128 x oversampled
Sample Rate	48 KHz
Reference Level	-10 dBu or +4 dBu
Frequency Response	±0.1 dB, 20 Hz to 20 KHz
Crosstalk	<106 dB
Dynamic Range	>106 dB

Optical Output

Number	One
Type	SD and ASI (SMPTE 297M, optical equivalent of 259M) HD (SMPTE 274M, 292M or 296M) (1550 non-CWDM by special order)
Wavelength	1310 nm (non-CWDM) (1550 non-CWDM by special order)
Power	-7 dBm
Max Cable Length	20 km (For greater distances, or higher power and larger loss budgets, please contact the factory)
Fiber Type	Single Mode Multi-mode compatible with 8 dB attenuation at transmit end
Connector	SC

Embedded Output (In Optical Output)

Group Assign	One of four groups
Channels	Two
Bit Depth	24 Bit

HD Standards Support:

1080i (SMPTE 274M -4,5,6)	50, 59.94 or 60 Hz
720p (SMPTE 296M -1,2,3)	50, 59.94 or 60 Hz
1080p (SMPTE 274M -9,10,11)	23.98, 24, 25 Hz
1080sF (RP211 -14,15,16)	23.98, 24, 25 Hz

Reference Input

Number	One
Type	1 V P-P Composite Video, PAL or NTSC or Tri-Level Sync
Impedance	75 Ω
Return Loss	>40 dB

General Specifications

Size	5.625" W x 0.8" H x 5.5" D (143 mm x 20 mm x 140 mm) including connectors
Weight	15 oz
Power	12 volts, 6 watts (100-230 VAC modular power supply not included)
Temperature Range	0 to 40° C ambient
Relative Humidity	0 to 95%, non-condensing

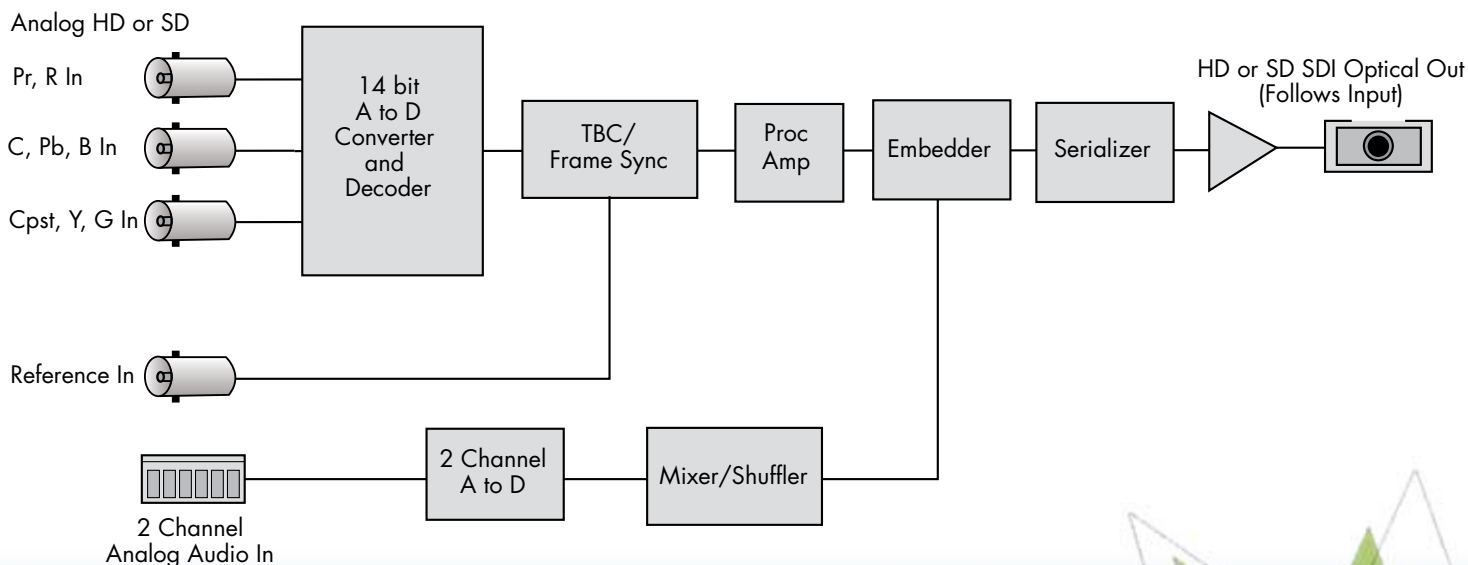

Analog SD In Yields SD SDI Out
Analog HD In Yields HD SDI Out